



ON Grid PV Inverter

user manual

Thank you for choosing non-isolated on-grid PV inverter. In order to ensure your safety and proper use, please read the manual in details before using. Thanks for your cooperation!



Contents

- 1. Overview 1
 - 1.1 Use of this manual 1
 - 1.2 Symbols 1
- 2. Description 2
 - 2.1. Brief Introductions 2
 - 2.2 General Introduction 3
- 3. Installation 5
 - 3.1 Installation Procedure 5
 - 3.2 Installation Preparation 5
 - 3.3 Mechanical Installation 10
 - 3.4 Electrical Connection 11
- 4. Monitoring 20
 - 4.1 Overview 20
- 5. Trial run 22
 - 5.1 Inspection before trial run 22
 - 5.2 Test run steps 22
- 6. Shut down & Dismantle 23
 - 6.1 Shut down 23
 - 6.2 Dismantle the inverter 23
 - 6.3 Discarding the inverter 23
- 7. Operating 24
 - 7.1 Working Mode 24
 - 7.2 Startup mode 26
 - 7.3 Power generation process 30
 - 7.4 Disconnect from grid 30
- 8. Maintenance 31
 - 8.1 Maintenance 31
 - 8.2 Troubleshooting 31
 - 8.3 Quality Assurance 33
- 9. Specification 34
 - 9.1 Specification 34

1

Overview

1.1 Use of this manual

This manual mainly introduces installation, operating and maintenance of inverter and related technical parameters. It is suitable for people who install the inverters and do other related jobs. Readers need to have some knowledge of electric, electrical wiring and mechanics. Before installing this product, please read this manual carefully, and put it in a suitable place, so as to ensure that relevant personnel of installation and operation can easily get it.

This manual applies to the following types of PV inverters

6/10/15/20/25K

1.2 Symbols

Please strictly follow below safety rules when installing and operating.



DANGEROUS

DANGEROUS indicates a hazard with a high level of risk which, if not avoided, will result in death or serious injury.



WARNING

WARNING indicates a hazard with a medium level of risk which, if not avoided, could result in death or serious injury.



CAUTION

CAUTION indicates a hazard with a low level of risk which, if not avoided, could result in minor or moderate injury.



NOTE

NOTE indicates a situation which, if not avoided, could result in equipment or property damage.

2

Description

2.1. Brief Introductions

On-grid PV power generation system usually is composed of solar panels, junction box, inverter, ammeter and power grid. The core of the system is PV grid-connected inverter. The sunshine irradiates on the surface of the solar panels, solar panels output DC, converted by inverter, then output AC of the same frequency and phase with the grid, and then feed into the grid.

series in application of PV power generation system is shown in Figure 2-1.

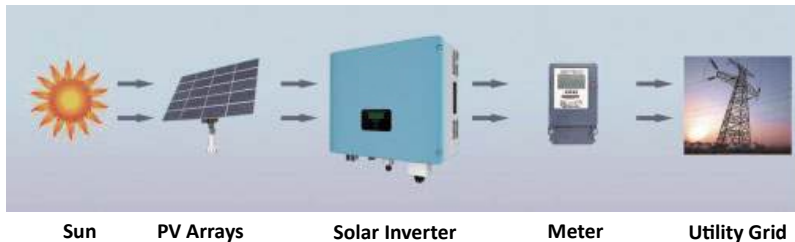

Fig 2-1 Grid-connected PV Power Generation System

Product performance

- Transformerless, highest efficiency is 98.8%
- Wide input voltage, MPPT efficiency is 99.9%
- Two way independent MPPT control to deal with different installation angles, enhance power generation
- Active and passive anti-islanding protection technology
- Comprehensive protection, higher reliability
- IP66 Outdoor design, suitable for harsh environment
- RS485,WIFI,GPRS multi-communication interface, user friendly.

2.2 General Introduction

✧ Appearance and interface



Fig 2-2 Appearance of 6~25K

Appearance of 6-25K (take 10K for example) is as shown in Figure 2-2. Its external interface is in the bottom of the machine and is composed of PV input port +, PV input port -, communication port, DC switch, AC output. Please refer to Figure 2-5 and Table 2-1 for details.

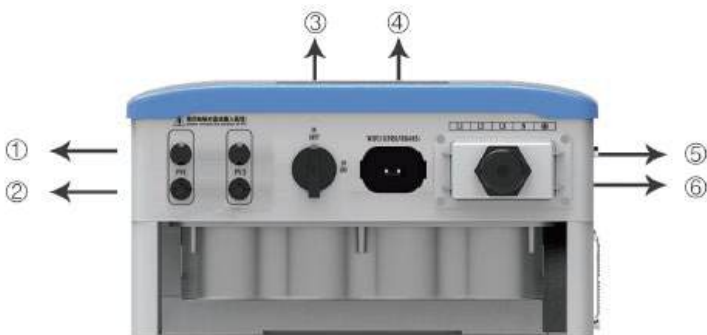

Fig 2-3: External Port

No.	Name	Description
1	PV input port +	Inverter's DC input port, connect with + port of PV arrays
2	PV input port -	Inverter's DC input port, connect with - port of PV arrays
3	DC switch	Electric cut off between inverter and PV arrays
4	WIFI/GPRS/RS485	Connect inverter with PC through this port for remote monitoring
5	Earthing bolt	Connect machine case with ground
6	AC output port	Connect with phase L1, L2, L3 and wire N of the grid through the breaker, connect ground wire to the ground

Table 2-1: External Interface

3

Installation

Please carefully read below installation guide for 6-25K.

3.1 Installation Procedure

Before installing and operating this product, please strictly abide by the installation sequence and warning symbols.

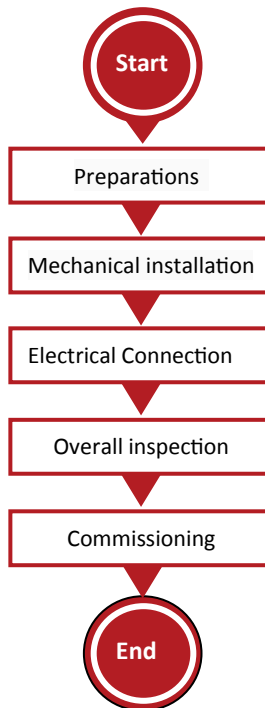

Fig 3-1 Installation procedure

3.2 Installation Preparation

- Check whether there is damage during transport

Although we have carefully tested and inspected the inverter before shipping, there might be damage during transport. So please check them before installation. If there is any damage, please contact the shipping company or directly contact us. Please provide photos of the damaged part. We will provide the best service as fast as possible.

● **Tools for installation**

The following installation tools and parts are needed.

- ✓ Spanner
- ✓ Electric impact drill
- ✓ Cross screwdriver
- ✓ M4 Allen wrench
- ✓ Megameter & Multimeter

● **Choose installation location**



WARNING

Please read carefully and follow the following basic installation requirements. Failure to follow these warnings will directly lead to serious personal injury or even life-threatening.



WARNING

Poor ventilation in the installation environment will affect system performance. It is necessary to ensure good ventilation during the operation of the equipment. The device must be kept upright and the heat sink is not blocked to ensure adequate cooling inside the device.

The inverter protection level reaches IP66 and can be used for indoor or outdoor installation.

Choosing the best installation location for the inverter plays a very important role in its safe operation, life guarantee, and performance guarantee.

1. Ensure that the installation wall has the capacity to support the inverter for a long time.
2. The inverter should be installed in a location that is easy for electrical connection, operation and maintenance.
3. The installation wall must have fireproof performance, and there must be no flammable materials or flammable gas in the installation space.

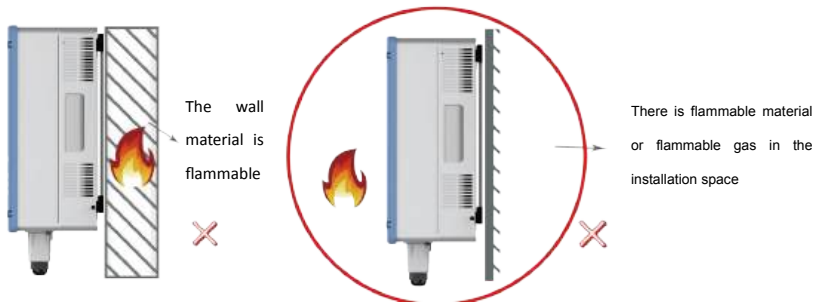

- 4. Do not install the inverter in the living area to avoid noise affecting daily life.
- 5. The installation location of the inverter should be far away from the reach of children.
- 6. Installation height is better to make the LCD at the same level with people's eye so as to make it convenient to operate on the LCD.



7. The inverter needs to be installed uprightly, and cannot be placed horizontally or upside down, or tilted.

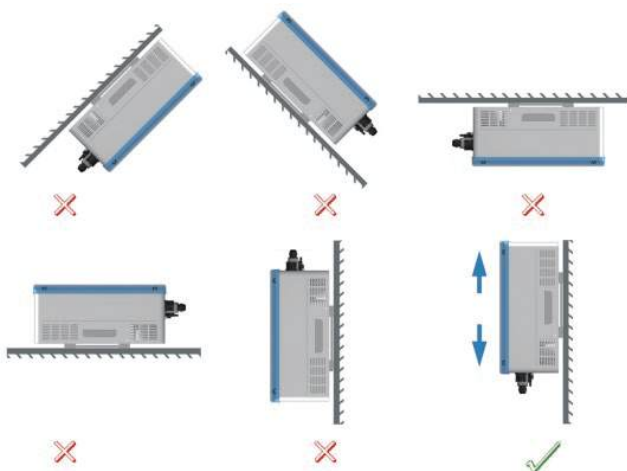

8. The temperature range of the installation environment should be between -25°C and 60°C , relative humidity. $\sim 95\%$ (When the ambient temperature exceeds 45°C , the output power of the inverter will decrease).



Minimum ambient temperature -25°C



Maximum ambient temperature 60°C



Environmental humidity: 0-95% non-condensing

9. Enough space surrounding the inverter is needed to ensure good heat dissipation.



10. Ensure that the inverter is ventilated and dissipated smoothly. It is strictly forbidden to install the inverter in a closed space, otherwise the inverter will not work normally, and there may even be a danger of explosion.

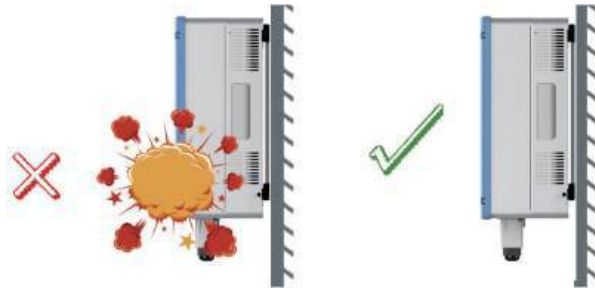

11. Multiple inverters can be installed side by side, and multiple rows of inverters need to be installed staggered to facilitate heat dissipation.

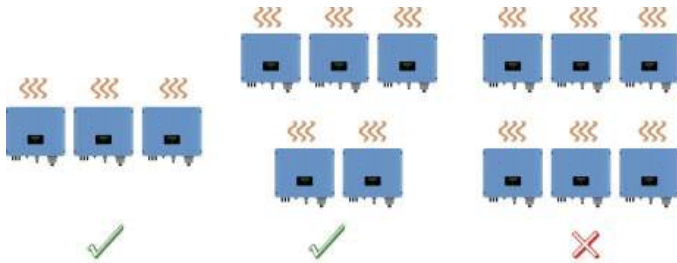

12. Please choose a place where you can avoid rain, snow, and direct sunlight for installation (sunlight, rain, snow, etc. will directly affect the service life of the inverter. If it is unavoidable, please shield the inverter reasonably. To ensure the best operating environment)



3.3 Mechanical Installation

After moving the inverter to the installation site, install the fixing bracket to the wall through the expansion bolt (expansion bolt is M8×30) assembly, and then install the inverter to the fixing bracket.

Installation:

1. Place the fixed bracket on the wall at a suitable height and position. Mark the drilling position according to the fixed bracket specification.

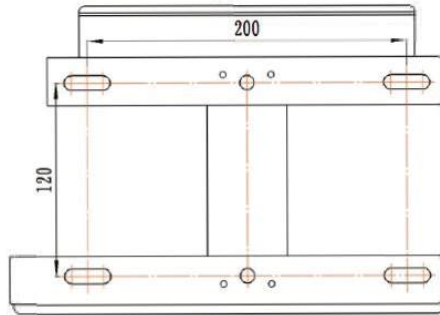

3-2 Installation size

2. Drill holes and install fixed brackets

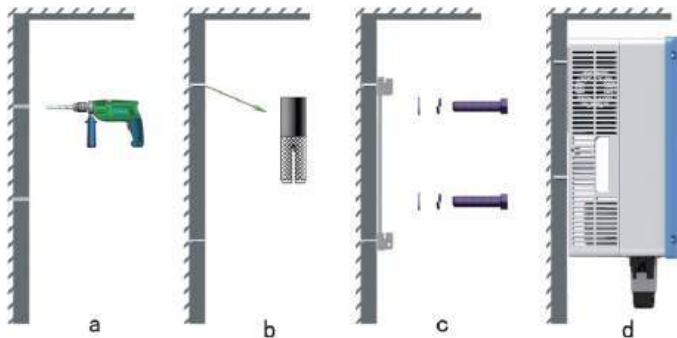

3-3 installation steps

If install the inverter on concrete wall

- Mark the drilling position on the wall according to the specifications of the fixing plate in Figure 3-2, and then drill at the marked position. A circular hole with a diameter of 10mm and a depth of 35mm.
- Insert the expansion coil of M8×30 into the round hole.
- Align the mounting holes of the fixing plate with the expansion solenoids and fix them with hexagonal bolts.
- Hang the inverter on the fixed bracket.

If install on metal scaffolds

Similar to drilling holes on the wall, drill holes according to the specifications of the fixing plate, fix the fixing plate with MS bolts, and hang the chassis on the fixing plate.

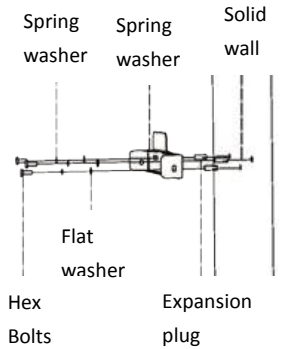

Note: Please cooperate with the machine before installing the fixed bracket to prevent reverse installation.

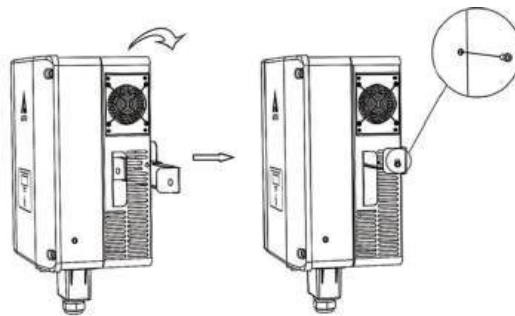

The inverter must be wall-mounted vertically

3.4 Electrical Connection

When performing electrical wiring work, personal protective equipment must be worn.



DANGEROUS

High voltage! Electrical shock!

Pay attention to safety before making electrical connections. Exposing photovoltaic strings to sunlight will generate dangerous high voltages.

Before making electrical connections, make sure that all cables are not live. Do not turn on the AC circuit breaker before completing the electrical connections..



WARNING

Any improper operation during the wiring process may cause equipment damage or personal injury or death.

The wiring operation must and only allow professional and technical personnel to complete.

The cables used in the photovoltaic power generation system must be firmly connected, intact, well insulated, and have the correct specifications.



NOTE

The relevant rules of the local power grid and the relevant safety instructions of the photovoltaic string must be followed.

All electrical installations must comply with the electrical standards of the country/region where the installation is located.

Only after getting permission from the local power supply department, can the inverter be integrated into the grid.

3.4.1 Terminal introduction

The external wiring terminal is located at the bottom of the inverter, as shown in the figure below:

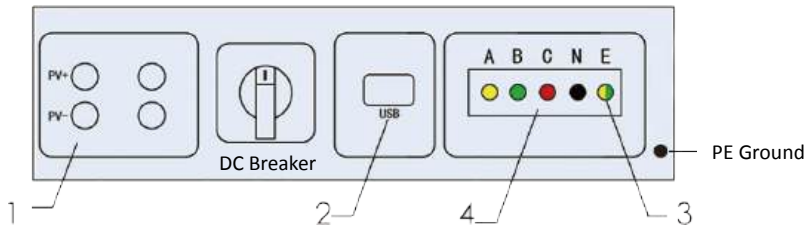

No.	Terminal	Description
1	PV input terminal	Inverter's DC input port, connect to solar panels.
2	RS485 interface	Used to connect to WiFi module or GPRS data acquisition module
3	PE terminal	For reliable grounding of the inverter
4	AC output terminal	Connect to the grid through the AC terminal

3.4.2 Wire Connection

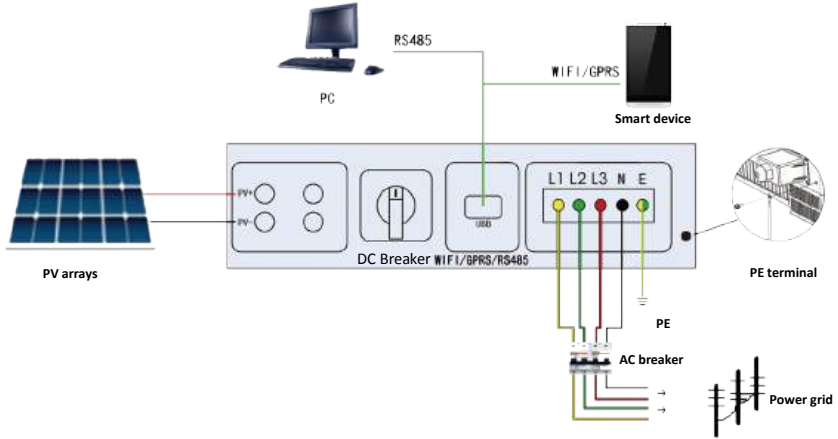

In the figure, the L1 phase of the power grid is represented by a yellow line, the L2 phase is represented by a green line, the L3 phase is represented by a red line, and the power grid N line is represented by a black line. It can be adaptive, and the N line can be omitted.) The protective grounding line is represented by a yellow-green line. It must be ensured that the inverter shell is reliably grounded.

3.4.3 AC Wiring



NOTE

The inverter can be connected to the grid only if the local power company or the competent authority has obtained the access permission. Before connecting to the grid, make sure that the grid voltage and frequency meet the requirements of the inverter.

● AC Circuit Breaker

An independent three-level or four-level circuit breaker on the AC side of each inverter can ensure that the inverter is safely disconnected from the grid.

No.	Inverter model	Breaker model
1	6K	16A
2	10K	32A
3	15K	40A
4	20/25K	60A



NOTE

Multiple inverters cannot share one circuit breaker

No load can be connected between the inverter and the circuit breaker

● **Leakage protector**

There is an integrated integrated leakage current detection unit inside the inverter. When the inverter detects a leakage current greater than the allowable value, it will quickly disconnect from the grid.

● **Parallel requirements for multiple inverters**

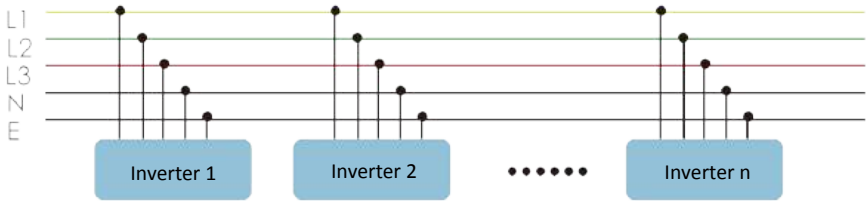

DANGEROUS

High voltage! Electrical shock!

Before electrical operation, make sure that all cables are not live.

Do not turn on the AC circuit breaker before the electrical connection of the inverter is completed

● **AC cable wiring steps**

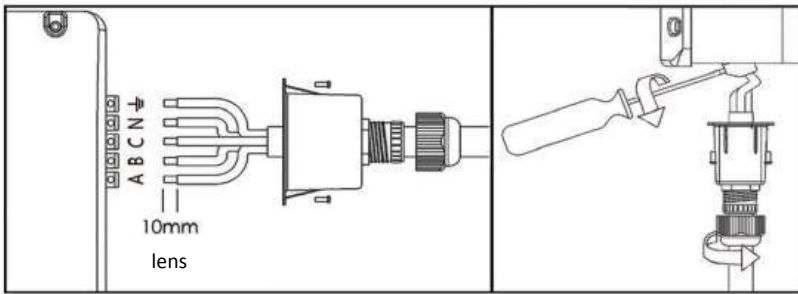

1. Turn off the AC side circuit breaker and place a "no power-on" sign to prevent it from being switched on.
2. Connect the AC side connector to the corresponding AC terminal at the bottom of the inverter.
3. Connect the "PE" cable to the ground.
4. Connect the live and neutral wires to the AC circuit breaker.
5. Connect the other end of the AC circuit breaker to the grid.
6. Check that all cables are firmly connected.

After fixing the AC cover, tighten the AC waterproof connector, as shown in the following figure

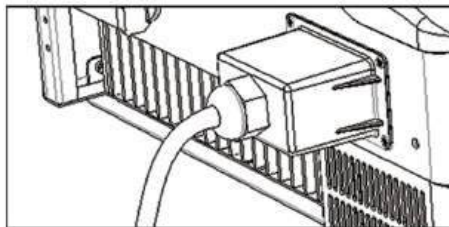



NOTE

1. Pay attention to the wiring terminal layout of the AC terminal. The live wire and the neutral wire cannot be reversed, otherwise the inverter may not operate normally.
2. The terminals on the other side of the inverter except for the AC side wiring terminals are all in-line.
3. Flexible copper cable is the best choice for AC side cable.
4. The grounding wire must be connected and well grounded.

Model	Distance between inverter and grid connecting point, corresponsive cable(cable diameter: mm 2)			
	10-30m	30-50m	50-80m	Above 80m
6K	4	4	6	When there is only one inverter in the project, try to avoid distance between inverter and grid connecting point more than 80m. When there are multiple inverters in project, it can firstly use combiner box to combine outputs of inverters, then choose cable with bigger diameter.
10K	4	6	6	
15/20K	6	10	10	
25K	16	20	25	

3.4.4 PV array connection



DANGEROUS

High voltage! Electrical shock!

Pay attention to safety before electrical connection. Exposure of PV array to sunlight will generate dangerous voltage.



WARNING

Before connecting the PV array to the inverter, ensure that the PV array is well insulated to the ground.

● PV array input configuration

The inverter has two PV array input areas PV1 and PV2, and the inverter is equipped with an MPPT tracker for each input area.



NOTE

The following two precautions must be met, otherwise, the damage to the inverter will be without the scope of the warranty.

- When designing a PV array, be sure to ensure that the voltage of each PV array is lower than 1100V even at the lowest temperature, otherwise it will cause irreversible damage to the inverter.
- Ensure that the maximum short-circuit current on the DC side is within the allowable range of the inverter, otherwise it may cause irreversible damage to the inverter.

The two PV string inputs operate independently, and each has an independent MPPT. Therefore, the two photovoltaic inputs can be different from each other, including: different panel types; different numbers of cells in the PV string; different inclination angles, different azimuth angles.



NOTE

In order to make full use of the DC input power, the PV strings of the same input should be close to the same (especially the voltage), including: the same model; the same number of panels; the same inclination angle; the same azimuth angle.

● PV array input connection

The PV input needs to be connected with plug-in PV input terminals, and plug-in terminals for quick connection to the PV input are provided in the scope of supply.

The DC cables on the PV string side need to be installed with DC connectors. The connector is already provided in the scope of supply.



NOTE

In order to ensure that the inverter reaches the IP66 protection level, only use the supplied connector or products with the same protection level.

● DC cable

DC cable requirements

Cross-sectional area	Cable outer diameter	Maximum withstand voltage	Maximum input current of each string
2.5~6mm ²	6-9mm ²	1100V	15A



NOTE

The maximum designed current of each DC terminal is not more than 15A

● DC cable connection steps



DANGEROUS

High voltage! Electrical shock!

There may be high voltage in the inverter!

Before electrical operation, make sure that all cables are not live.

Before the electrical connection of the inverter is completed, the AC circuit breaker switch shall not be installed.

1. This series of connectors only supports multi-strand copper wires. Cut and strip as required, the stripping length is 7-8mm.

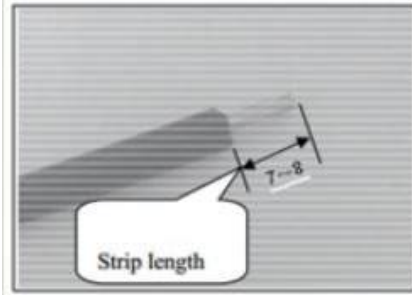

2. Crimp the wire. Place the terminal correctly in the terminal crimping pliers, then put the bare copper wire part of the cable into the terminal opening slot and press it firmly. Be careful not to damage the terminals and the copper wires of the wires.

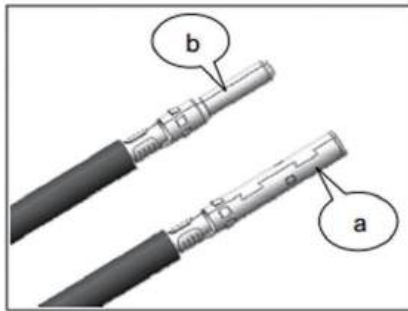

a-female terminal b-male terminal

3. Insert the terminals into the main body of the plastic case. Correctly insert the corresponding plastic case according to the positive and negative polarity. You can gently pull the wire in the reverse direction to verify whether the connection is firm.

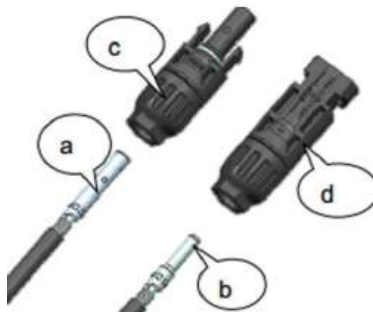

a-female terminal b-male terminal
 c-male housing body d-female housing body



WARNING

When wiring the PV cable, the positive and negative poles must be connected correctly. Please cut off the power of the system and verify whether the male and female connectors are of the same model before use.

4. After the cable is plugged in, use a special wrench or adjustable wrench to tighten the nut. In order to achieve better results, two wrenches can be used to work together.

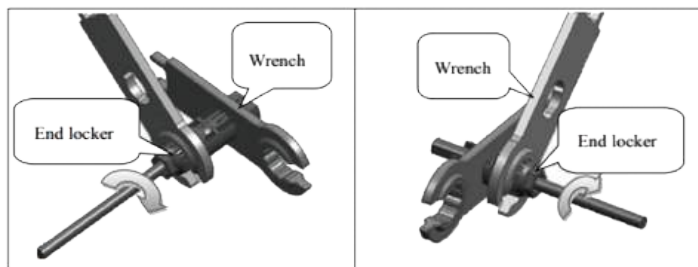

5. Connect the male head and the female head, align the buckle on the male head with the groove on the female head and insert, there will be a crisp sound when connected.



WARNING

1. The maximum DC input voltage of the two sets of PV arrays connected to MPP Tracker A and MPP Tracker B must be less than 1100V, and the MPP working voltage must be between 250V and 1000V. The specifications and installation methods of the two sets of PV arrays may be inconsistent.
2. When two sets of PV arrays connected to MPP Tracker A (MPP Tracker B) are connected in parallel, the specifications and installation methods of the two sets of PV arrays must be consistent, otherwise the power generation of the PV system will be affected! If the voltage difference between the two sets of PV arrays is greater than 5%, an arc may occur when the battery panels are plugged in and out, which will burn out the PV plug and even cause personal injury.

- Grounding



WARNING

Since the inverter is a transformerless type, it is required that the positive and negative poles of the photovoltaic string cannot be grounded, otherwise the inverter will not operate normally.

Grounding system

In this PV power generation system, all non-current-carrying metal parts and equipment housings should be grounded (such as the bracket of the PV arrays, the inverter housing, etc.).

A single inverter system needs to ground the "PE" cable.

Multiple inverter systems support multi-point grounding, but all inverter "PE" cables and the grounding points of the metal frame of the PV array need to be connected to the equipotential line (depending on site conditions) to achieve equipotential connection .

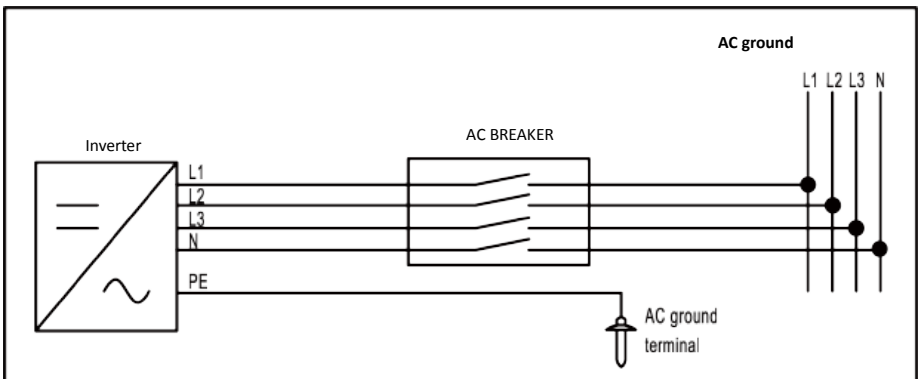
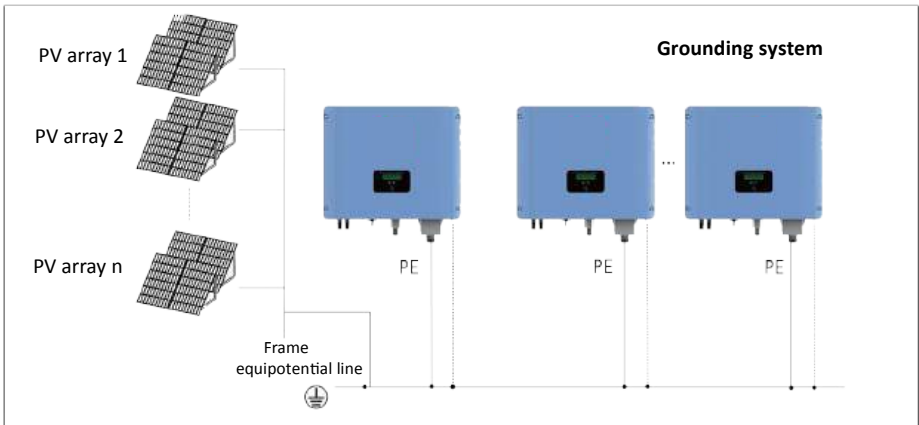

4

Monitoring

4.1 Overview

The inverter has a variety of communication methods. When users need to monitor the operation information of the photovoltaic power generation system, we provide the communication system solutions shown in Figures 4-1 and 4-2.

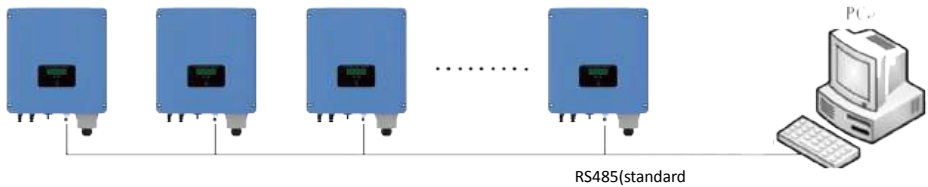

Figure 4-1 RS485 (standard MODBUS protocol) communication system mode

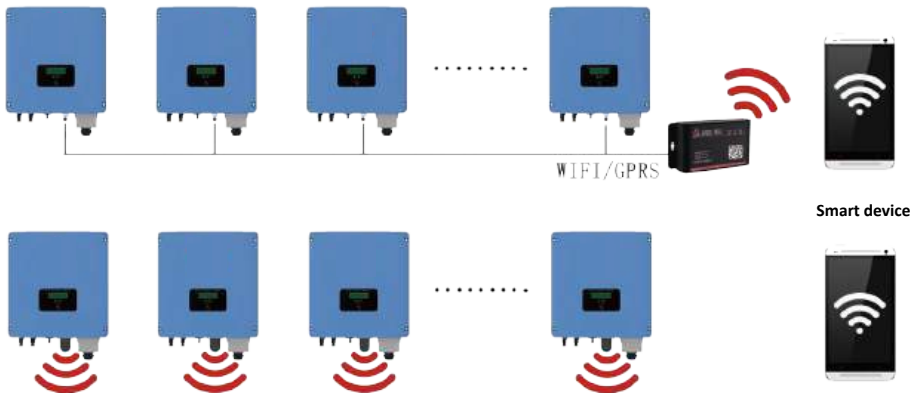
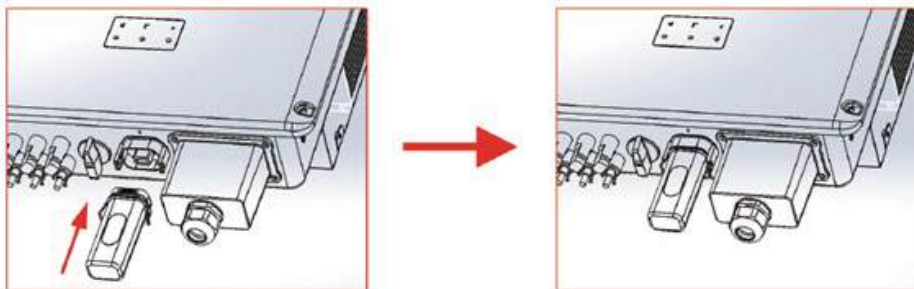

Figure 4-2 WIFI/GPRS communication system mode

After installing the GPRS data collection module or Wi-Fi data collector module, you can monitor the operation of the entire photovoltaic system through our company's App program App or our company's cloud server .

- Collector description



5

Trial run

Trial run is an important step in the installation of PV systems. Correct trial operation can prevent system fires, electric shocks and other accidents.

5.1 Inspection before trial run

Before turning on the inverter for the first time, you need to do the following inspections.

Environmental inspection

- 1). The installation position of the inverter is convenient for operation and maintenance.
- 2). Reconfirm that the inverter is installed firmly.
- 3). Good ventilation.
- 4). No external objects or parts are left on the top of the inverter.
- 5). The accessories around the inverter are correctly connected.
- 6). Cables are reasonably distributed, well protected and will not be mechanically damaged.
- 7). Reasonable selection of AC circuit breaker.
- 8). The vacant terminal has been sealed.
- 9). All safety signs and warning labels on the inverter are firmly pasted and clearly visible.

5.2 Test run steps

If all the above inspections have passed, the inverter can perform the following trial operation steps for the first startup.

- 1) Make sure that the above inspection items meet the requirements.
- 2) The AC side circuit breaker is placed in the "ON" position.
- 3) Rotate the DC switch to the "ON" position.

Assuming sufficient light and power grid conditions meet the conditions:

The PV array is initialized and begins to provide power.

The grid-connected inverter starts to charge the DC bus.

The inverter start generate AC power,and AC power into the power grid.

- 4) Observe the status of the control panel

6s & Dismantle

6.1 Shut down

In normal operation, there is no need to shut down the inverter manually, but it is necessary to shut down the inverter during maintenance or repair. To disconnect the inverter from the AC and DC power supply, follow the steps below, otherwise it may cause personal injury or death or equipment damage.

- 1) Disconnect the external AC circuit breaker and prevent reconnection due to misoperation.
- 2) Turn the DC switch to the "OFF" position and unplug all DC string inputs.
- 3) Wait for about 10 minutes until the internal capacitor is discharged.
- 4) At the AC terminal, measure the AC-to-ground voltage to confirm that the AC output voltage of the inverter at the AC circuit breaker is zero.
- 5) Remove the DC connection cable.
- 6) Remove the AC connection cable.



NOTE

Please strictly follow the above steps, otherwise the inverter will not work normally.

6.2 Dismantle the inverter

The user can dismantle the inverter according to the above electrical installation and mechanical installation and follow the reverse steps.

6.3 Discarding the inverter

For inverters that will no longer be put into operation in the future, users need to properly dispose of them by themselves. (The control panel, batteries, modules and other components contained in the inverter may pollute the environment. Users need to properly dispose of them in accordance with relevant local laws and regulations.)

7 Operating

7.1 Working Mode

The working modes of the inverter include-start mode, run mode, and standby mode. In each working mode, the LCD displays corresponding information.

7.1 .1 Control panel with LCD display

The panel of the series grid-connected PV inverter includes a LCD display. In order to better carry out the interactive operation of the man-machine interface, two LED indicator and a voice switch are set on the panel, as shown in Figure 7-1.

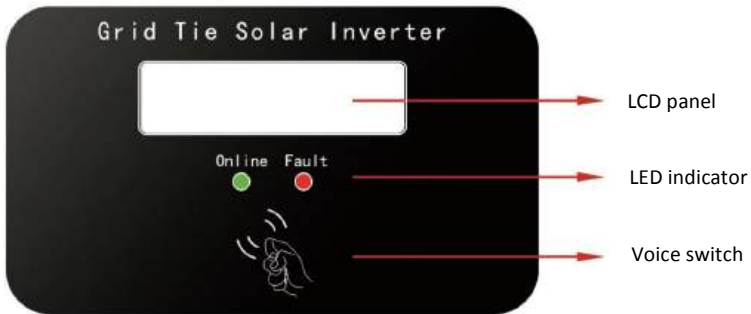



Figure 7-1 series LCD control panel

LED display status

No.	LED indicator	Description
1	Online	Grid-connected operation indicator (normal operation, grid-connected power generation indicator is on)
2	Fault	Fault indicator (lights on when a fault occurs)

The use of voice switch

Tap the picture icon  on the panel, the display interface of the LCD panel is switched

7.1.2 Control panel with indicator light only

For the indicator panel of the series grid-connected photovoltaic inverter, in order to better carry out the interactive operation of the man-machine interface, 3 LED lights are set on the panel, as shown in Figure 7-2.

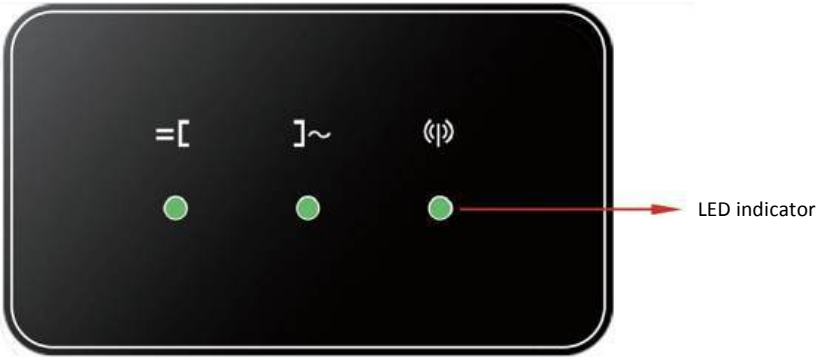

Figure 7-2 series indicator panel

● LED display status

Function	Status		Description
	= [] ~	
Running			Grid-connected and power generation
			DC is normal, AC is not powered on
			DC is normal, grid-connected standby
			Equipment failure
			DC is not powered on
Communication			
			The communication cable or communication module is connected, and there is data interaction on the communication channel
			The communication cable or communication module is not connected or there is no data interaction on the communication channel
Light ON Light OFF light flashes			

Table7-2 LED display status and display meaning

The working modes of the inverter include-start mode, run mode, settings mode and standby mode. In each working mode, the LCD displays corresponding information.

7.1 .3 Control panel with LCD display









The panel of the series grid-connected PV inverter includes an LCD display. In order to better carry out the interactive operation of the man-machine interface, four LED indicators and two touch keys are set on the panel, as shown in Figure 7-3.



Figure 7-3 series LCD control panel

● LED display status

The status information of LED lights is shown in Figure 7-4.

LED INDICATOR		
INDICATOR	STATUS	EXPLANATION
=[	DC power on
		DC power off
]~		Operating in grid-tied mode
		Grid connected activated but not Operating
(P)		Communication is in progress
		No communication
⚠		Fault
		No fault



Steady green:  Blinking green:  Off: 

Figure 7-4 LED display status

7.2 Startup mode

The start mode means that the light conditions meet the DC start conditions of the inverter, but the grid has not yet been connected to power generation. In this mode, the inverter information is displayed in sequence. After the display is completed, the inverter meets the grid-connected conditions and switches from the startup mode to the running mode, otherwise, it switches to the standby mode.

The screen display sequence of the startup mode is shown in Figure 7-5 (take 10K as an example).

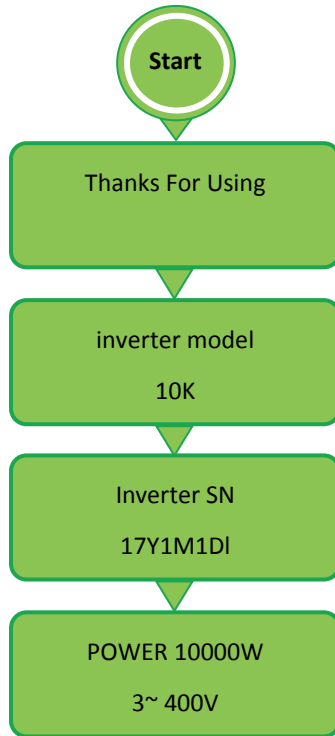

Figure 7-5 Start interface



NOTE

After the PV array voltage > 250V, the system will count down for 20 seconds. Within 20 seconds, the PV array voltage will always meet the grid-connected power generation requirements before it will switch to the operation mode.

● Running mode:

In the Running mode, the inverter converts the DC power of the photovoltaic array into AC power and integrates it into the grid. At the same time, the inverter always outputs the maximum energy in the maximum power point tracking (MPPT) mode.

In the running mode, the display content of the LCD liquid crystal display is refreshed every two seconds, so the display content is only valid within the current 2 seconds. The display screen has the default display content. 5 seconds after entering the normal operation state, the LCD displays the default interface, as shown in Figure 7-6.



Figure 7-6 Default interface of running mode

In running mode, the screen display content is shown in Figure 7-7 and 7-8 (take 10K as an example).

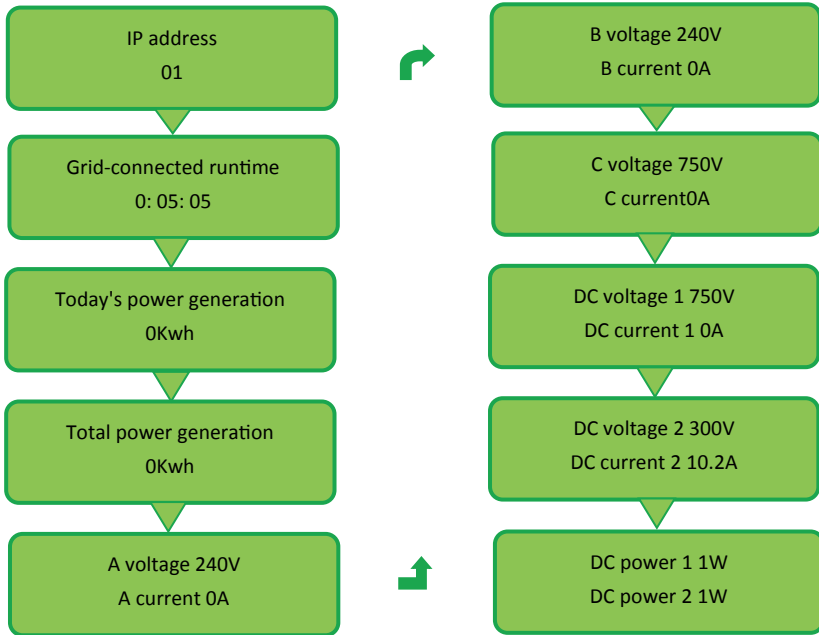

Figure 7-7 Normal interface of running mode

Note: Tap the position of the voice control switch mark, the LCD screen background display light is on, and the switching interface is displayed at the same time, the switching display content is shown in Figure 7-5, no operation within 20 seconds, the background light is off, and the LCD screen returns to the default interface.



NOTE

Tap the voice switch  to switch the content displayed on the LCD



NOTE

If the DC side cuts off the power supply and is powered on again, the inverter will start to recalculate the total power generation for that day according to the new day.

● Standby mode

DC start and the grid connection conditions are not met, it is the standby mode.

In the standby mode, the inverter continuously detects whether the grid-connected power generation conditions are met, and after a 20-second countdown, the inverter switches from the standby mode to the running mode.

In standby mode, the second line of the LCD default interface displays standby information in cycles. The possible standby information is shown in Figure 7-6, one or more of them; tap the front panel to switch to other View detailed information on the interface; in standby mode, the content displayed by screen switching is shown in Figure 7-9 (take 10K as an example)

Figure 7-8 Information displayed cyclically in standby mode

Standby System abnormal	Standby DC bus voltage is low
Standby DC 1 over current	Standby Phase A over voltage
Standby Hardware protection	Standby Phase A under voltage
Standby AC side overheated	Standby DC 1 under voltage
Standby Neutral point imbalance	Standby Inverter off grid
Standby Phase lock abnormal	Standby Phase B over voltage
Standby DC bus voltage is high	Standby Phase C over voltage

Note: Tap the position of the voice control switch mark, the LCD screen background display light is on, and the switching interface is displayed at the same time, the switching display content is shown in Figure 7-5, no operation within 20 seconds, the background light is off, and the LCD screen returns to the default interface.



NOTE

Tap the voice switch  to switch the content displayed on the LCD

- Switching of working mode

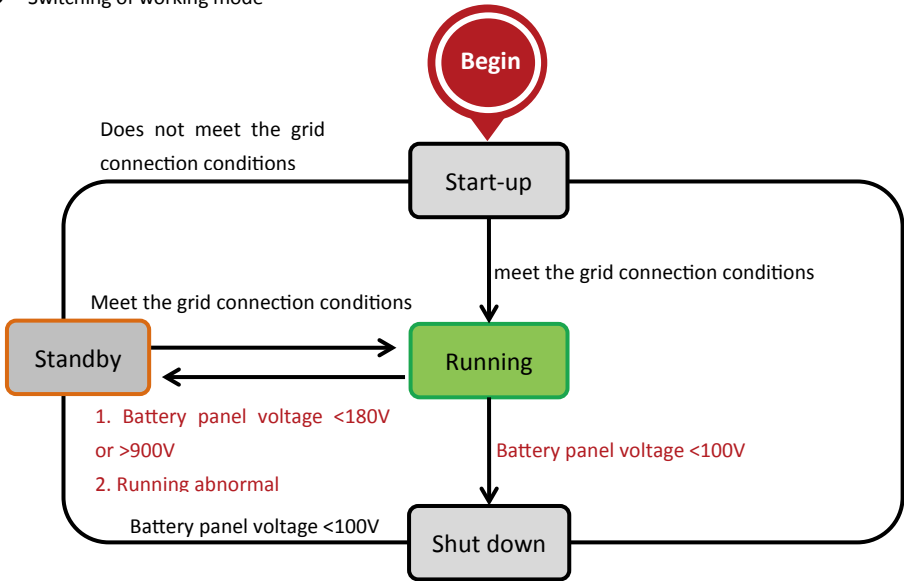

Figure 7-9 Switching of working mode

7.3 Power generation process

On grid generating capacity process is automatic, described as follows:

1. Switch on DC and AC circuit breakers, the inverter will enter start-up mode.
2. If input voltage on DC side exceeds 300V, AC side voltage in range 310Vac~480Vac, and grid frequency is normal, inverter begins countdown.
3. The DC side starts after a countdown of 20 seconds;
4. After the DC bus voltage stabilizes, the inverter side starts to work and connects to the grid for power generation.

7.4 Disconnect from grid

When the grid has below abnormal situation, inverter will disconnect from the grid immediately.

- The grid voltage is outside the normal range of 310V-480V;
- The grid frequency is outside the normal range of 45-55Hz/55-65Hz;
- The voltage of the photovoltaic array is outside the allowable working range of the inverter;
- The ambient temperature is outside the allowable working range of the inverter.

**DANGEROUS**

Do not open the machine. Users trying to repair the machine by themselves may cause electric shock and fire hazard.

8.1 Maintenance

Due to the influence of ambient temperature, humidity, dust and vibration, the internal components of the inverter will age and wear, which will affect the service life of the inverter. Therefore, daily and regular maintenance of the inverter should be carried out to ensure its normal Operation and service life.

- Clean the dust and debris from the radiator frequently.
- When dust accumulates on the photovoltaic array, clean the photovoltaic array with water, and the cleaning should be carried out when the weather is cool.
- Check the system regularly to ensure that all wiring and supply conditions are error-free.
- Always read the information on the LCD display to understand the changes in the inverter's working status.

**WARNING**

Never use a pressure washer to clean the inverter, or other cleaning methods that may cause water to enter the machine.

8.2 Troubleshooting**WARNING**

Only qualified engineers can repair the inverter!

Most errors and malfunctions will be displayed. The following table proposes solutions to several possible problems.

Table.8-1.troubleshooting

No.	Failure	solution
1	LED indicator and LCD screen do not light up	1. Disconnect AC side circuit breaker 2. Disconnect DC side circuit breaker 3. Check the input voltage of the PV array (whether it is lower than 300V) and the grid voltage 4.If the above conditions are met, check the circuit breaker
2	"on line" indicator goes off	1. Disconnect AC side circuit breaker 2. Disconnect DC side circuit breaker 3.Check whether the parameters on the AC and DC sides meet the startup requirements. If the parameters meet the requirements, check the wiring according to 4.4 Electrical connection
3	Abnormal DC voltage (DC voltage>1100v or <250V)	1. Disconnect AC side circuit breaker 2. Disconnect DC side circuit breaker 3. Check whether the voltage of each group of PV array meets the range of 300V-900VDC 4. When the DC voltage is restored to the allowable range of the inverter, restart the inverter
4	The grid voltage is abnormal (the grid voltage>450V or <310VAC)	1. Disconnect AC side circuit breaker 2. Disconnect DC side circuit breaker 3.Detect the voltage on the AC side 4.4. If the grid voltage is not within the allowable voltage range of the inverter, please contact the local power company to adjust the grid voltage
5	The grid frequency is abnormal (the grid frequency is neither 45-55Hz nor 55-65Hz)	1. Disconnect AC side circuit breaker 2. Disconnect DC side circuit breaker 3.Detect the frequency on the AC side 4.If the current grid frequency is not in the inverter's allowable frequency range, please contact the local power company to adjust the grid frequency
6	The temperature is too high (inverter temperature is too high)	1. Disconnect AC side circuit breaker 2. Disconnect DC side circuit breaker 3. Check whether the ambient temperature is higher than 60 ℃ or lower than -25 ℃ 4. Please check whether the ventilation of the machine is normal,

		whether the hook-up installation is correct, and whether the air duct is unblocked
		5. Whether the output power exceeds the rated value
7	Abnormal grounding	1. Disconnect AC side circuit breaker
		2. Disconnect DC side circuit breaker
		3. Check whether the ground resistance of each group of PV arrays is greater than 2MΩ

If the fault cannot be solved or your problem is not mentioned in the above table, please contact us.

8.3 Quality Assurance

● warranty

The warranty period of this product is subject to the contract.

● Conditions

1. Our company will offer free repair service or replace with new product for faults during the warranty.
2. The replaced unqualified product will be returned to our company.
3. Customers need to give our company reasonable time to deal with the machine fault.

● Our company will not be liable for the following cases.

1. Transportation damage
2. Improper installation
3. Improper modification
4. Incorrect use
5. Very harsh environment that is beyond the specified in this manual
6. Any installation and use that is beyond the relative international standards
7. Damages caused by improper natural environment

MODEL	6KTLC	10KTLC	15KTLC	20KTLC	25KTLC
Input(DC)					
Max. DC input power	9000W	15000W	22500W	30000W	37500W
Max. DC input voltage	1100V				
MPPT voltage range	180-1000V				
Max. DC current	20/20A	20/20A	20/30A	30/30A	40/30A
Recommended MPPT operating voltage	650V				
Starting voltage	180V				
No.of MPPT	2				
Max. no.of strings per MPPT	1/1	1/1	1/2	2/2	2/2
Output(AC)					
Rated output power	6000W	10000W	15000W	20000W	25000W
Max. output power	6.6kVA	11kVA	16.5kVA	22kVA	27.5kVA
Max. output current	10A	16.7A	24A	32A	41A
Rated grid voltage	400V				
Grid voltage range	310-480Vac				
Rated grid frequency	50Hz/60Hz				
Grid frequency range	45-55Hz/55-65Hz				
THD	<2%(Under the rated power)				
Power factor	>0.99(Under the rated power)/Adjustable range: 0.8(Leading)-0.8(Lagging)				
DC current injection	<0.5%(Under the rated power)				
System Data					
Max. Efficiency(%)	98.5%	98.6%	98.7%	98.8%	98.8%
Euro. Efficiency(%)	98%	98.2%	98.2%	98.2%	98.2%
Humidity range	0-100%, non-condensing				
Cooling type	Intelligent forced air cooling				
Temperature range	-25-60°C				
Power Consumption at night	<1W				
Max. operating altitude	4000m				
Display	LED(Optional:LCD)				
Communication interface	WIFI(Optional: RS485 or GPRS)				
Protection					
DC reverse-polarity protection	Yes				
Short circuit protection	Yes				
Output over current protection	Yes				
Output over voltage protection	Yes				
Insulation resistance monitoring	Yes				
Residual current detection	Yes				
Surge protection	Yes				
Grid monitoring	Yes				
Islanding protection	Yes				
Temperature protection	Yes				
Integrated DC switch	Yes				
Mechanical Data					
Size (width x height x depth)	427x450x204mm				
Weight	15kg	15kg	15kg	18kg	18kg
Protection class	IP66				
Standard					
Safety standard/EMC standard	NB/T32004-2018, IEC62109, IEC61000, IS16169 & IS16221(BIS)				
Grid-connected standard	IEC61727, EN50549-1, VDE-4105, NRS-097-2-1, OVE-Richtlinie R25, UNE217001/2, Ordinance No.140				
Other standard	IEC61683, IEC62116, EN50530, IEC60068				



SUNRISE ENERGY CO., LTD

Tel: +86-519-81688389

E-mail: info@sunriseenergy.cn

Add: No.20 Tongzi River West Road, Zhonglou Development Zone, Changzhou, Jiangsu,China